

HOPPER SPREADER

*The best performing
hopper spreader line*

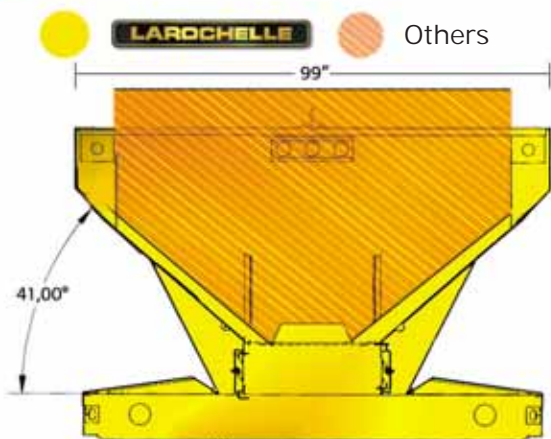

HOPPER SPREADER



Superior design & engineering

- Open underbody structure for easier maintenance and clean-up
- Welded fenders (not bolted) for added durability
- Replaceable bolted conveyor floor (not welded)



LAROCHELLE offers you more than any of the other manufacturer

- 99" wide hopper construction providing up to 1 extra cu. yd. capacity
- Low center of gravity hopper design
- 41° slope on sides
- Sloped fenders to prevent snow build-up

LAROCHELLE



Rear spinner configuration (SC model)
 Stretched out conveyor design allows the installation
 of a rear spinner without any major modifications

EXCLUSIVE FEATURES

Longitudinal conveyor construction :
 stronger than competition

- Driving shaft : 1 3/4"
- Conveyor chain (88K)
 tougher than competition (667X)
- Extra-life sprocket with double shoulders
 for longer chain life
- Flat bar with bent extremities,
 welded on each side

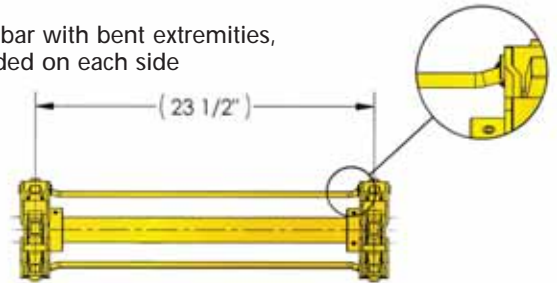

- Completely sealed lighting system

OPTIONS



- Auger type cross conveyor
 (spreading left, right or both sides simultaneously)



- Removable
 protective
 sub-plate
 (return of chain)
 Prevent aggregates
 build-up on truck
 components

- Electronic spreading control
- Pre-wetting system
- Top screens
- Polyurethane spinner
- Flashing amber lights kit (4)
- Spinner deflector
- Rear ladder with safety guardrail

MODEL	DC702 SC702	DC902 SC902	DC1202 SC1202	DC1402 SC1402
Capacity	7 cu. yd.	9 cu. yd.	12 cu. yd.	14 cu. yd.
Truck application	Single axle	Single axle	Tandem	Tandem
Recommended C.A.	84"	102" @ 108"	102" @ 108"	120" @ 132"
Hopper length	120"	144"	168"	192"
Overall length	132"	156"	180"	204"
Hopper width	99"	99"	99"	99"
Overall height	65"	65"	65"	65"

* DC: Longitudinal conveyor + Cross conveyor with left hand side spinner
 * SC: Longitudinal conveyor with rear mounted spinner
 * SC: Available in removeable "slide-in" configuration for dump body

LAROCHELLE products are warranted under published warranty. The company reserves the right under its product improvement policy to change construction or design of its product without notice.

Larochelle Equipment Inc. quality management
 SYSTEM IS ISO 9001: 2000 CERTIFIED.



Since 1956
 250, 2nd avenue, Quebec, P.Q., Canada, G1L 3A7
 Tel. : (418) 522-8222 ● Fax : (418) 522-3115
 E-mail : phil@larochelle.ca ● Internet : www.larochelle.ca

DISTRIBUTOR