

LAROCHELLE®

ISO 9001 : 2000

Since 1956

Underbody

SCRAPER/GRADER

THE ULTIMATE IN TRUCK MOUNTED SCRAPER/GRADER TECHNOLOGY

- The Larochelle underbody scraper/grader transforms your plow truck into a multi-purpose truck.
- Scrape and plow to the bare road surface to help reduce salting and sanding to a minimum.
- Recondition your gravel road surface all year long.

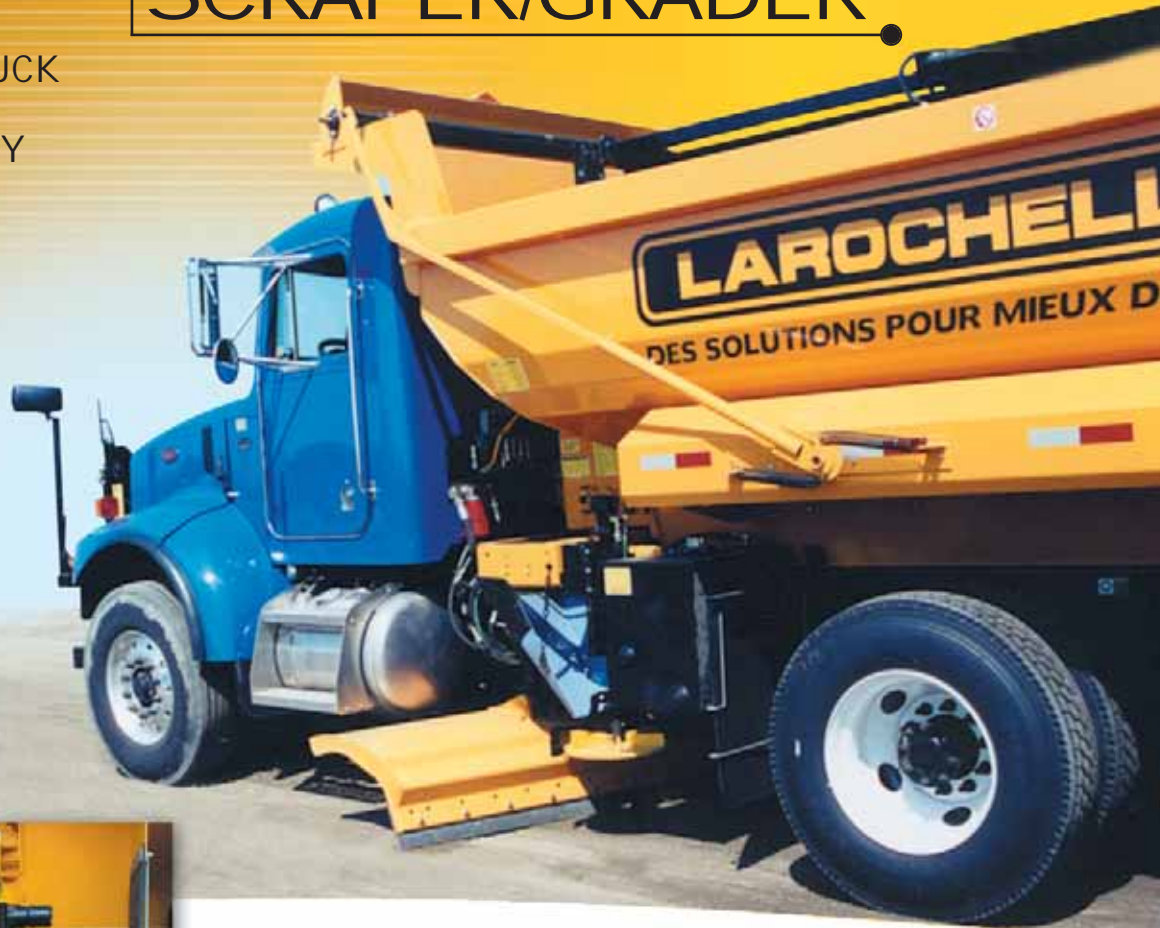

EXCLUSIVE FEATURES

- Quick mounting and removal in less than 20 minutes
- Framerrail flange mount design for either stationary or power angling units
 - Eliminates the need for a heavy underslung semi-circular pivot table
 - Substantially reduce maintenance and corrosion
 - Allows easy access to truck underchassis drive components
- Can be installed even with a L.H. side spinner
- Boxed type moldboard construction, high strength steel
- Cutting edge wear compensators screw jacks
- All hydraulic operation for all functions
- Adjustable scraping pressure over road surface by a specially designed hydraulic system
 - No use of air bags that cannot perform in hard packed and deep snow conditions
 - The nitrogen accumulator responds to road sudden obstacles such as man hole cover hits

Model " LSF "

Select model that best suit your application

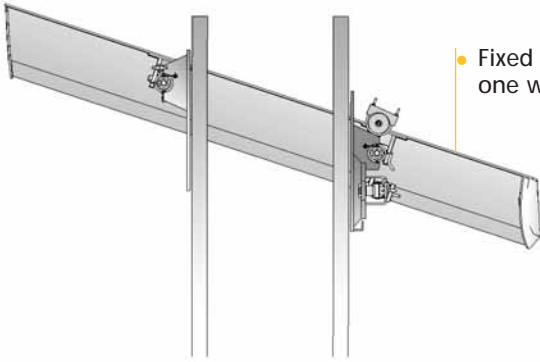

• Fixed angle one way

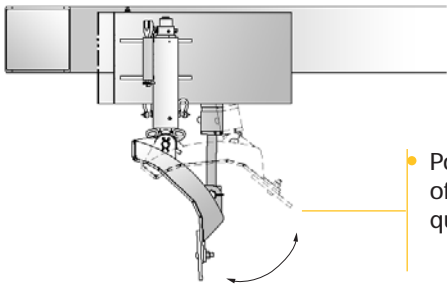

• Power up and down of moldboard through a quick detachable cylinder

Model " LGS "

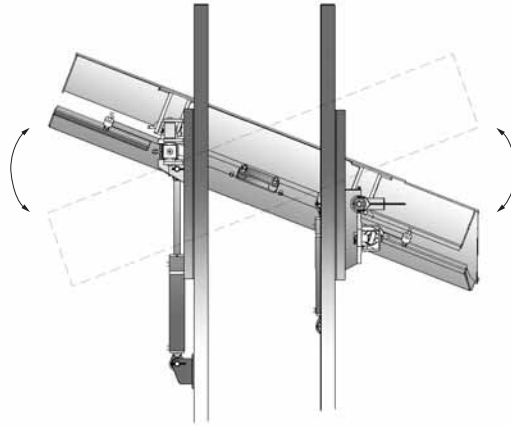

• Adjustable pivoting angle moldboard up to 45°

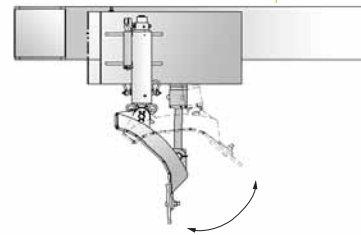

• Power up and down of moldboard through a quick detachable cylinder

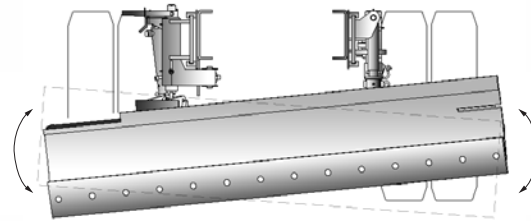

• Hydraulic tilt of moldboard

options

- Hydraulic moldboard extensions (model LGS only)
- Curved type cutting edge
- Serrated type cutting edge



MODEL	LENGTH	HEIGHT	SCRAPING WIDTH AT 45°	PIVOTING ANGLE
LSF920	9' 0"	20"	8' 4"	-
LSF1020	10' 0"	20"	9' 3"	-
LSF1120	11' 0"	20"	10' 4"	-
LGS920	9' 0"	20"	8' 4"	45°
LGS1020	10' 0"	20"	9' 3"	45°
LGS1120	11' 0"	20"	10' 4"	45°

* Other models and options available upon request.

LAROCHELLE products are warranted under published warranty. The company reserves the right under its product improvement policy to change construction or design of its product without notice.

Larochelle Equipment inc. quality management SYSTEM IS ISO 9001: 2000 CERTIFIED.



Since 1956
250, 2nd avenue, Quebec, P.Q., Canada, G1L 3A7
Tel. : (418) 522-8222 • Fax : (418) 522-3115
E-mail : phil@larochelle.ca • Internet : www.larochelle.ca

DISTRIBUTOR